

WE OFFER

- Standard Chemical Feed Systems
- Controls / Controllers
- Metering Pumps
- Custom Engineered Systems
- On-Site Oxidant Generation
- Polymer Feed Systems
- Chemical Storage & Accessories
- Booster Skids
- Performance Monitoring Tools
- Transfer Pumps
- Level Monitoring
- Web Based Remote Monitoring
- Instrumentation
- Flow Measurement
- Innovative Accessories

SPECIALIZED SERVICES

- System Installations
- Start Up & Commissioning
- Contract Maintenance
- Emergency Repairs
- Plant Audits / System Surveys
- Pump/ Accessory Repairs
- Equipment Pool Management
- Equipment Rentals
- Controller Maintenance & Repair

MARKETS SERVED

- Industrial
- Municipal
- Commercial
- Recreational

1364 Hamilton Parkway
Itasca, Illinois 60143
Toll Free 888-200-1800
Phone: 630-351-9070
Fax: 630-351-9080

www.equip-solutions.com

Simple Pump Skids—CF Series



CF200 Series

- ◆ Dual Pump Configuration
- ◆ Designed for ANY Solenoid Metering Pumps—You Choose!
- ◆ Pre-Plumbed , All piping & fittings CPVC
- ◆ Ready to Install, No Assembly Required
- ◆ Convenient and Economical
- ◆ Reduces Hassle & Labor
- ◆ Expandable Choices and Sophistication
- ◆ Rapid Delivery

The CF Series of pump skids offer maximum flexibility and economy.

These systems offer a convenient package for either single or dual pump applications and are ideal for a wide range of water treatment applications.

The CF Series systems permit the user to acquire these pre-plumbed systems and add the pumps on-site or select the desired brand of metering pump/s to be installed and tested prior to delivery.

The Basic CF 100 Series Skids include:

- Base & Back Plane 36" x 24" x 40"
- Containment Drip Rim
- Calibration Assembly
- Discharge Pressure Gauge
- On-Board Power Receptacle
- NPT Inlet / Outlet Connections
- Pump Pedestals
- Inlet Y Strainer

The system components and design can be expanded to add functionality.

The upgraded CF Dual Skid 200 (shown above) offers the same flexibility of choice but adds a back pressure valve to help ensure pump accuracy and an added NEMA 4X control panel for control wiring and main power.

The control panel provides dual Hand Off Auto switches that allow the pumps to be run manually or automatically from a remote signal.

Options for the 200 Series include feed verification, automatic switchover and the addition of an on-board controller such as pH, ORP or timer packages.

Ask about installation and Start Up!

Simple Pump Skids — CF Series

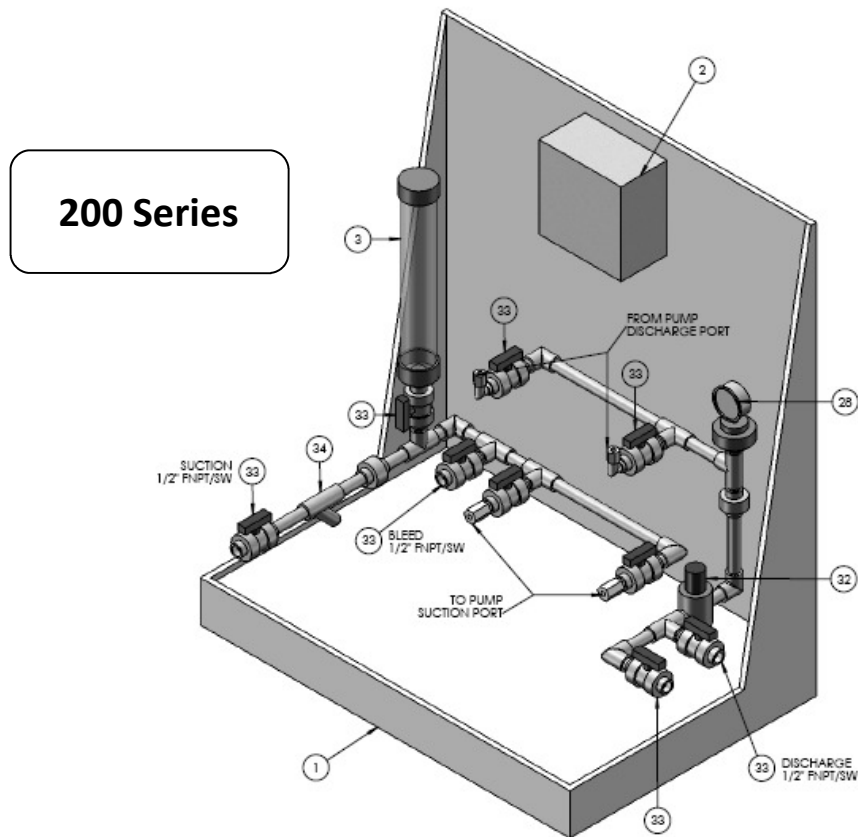

- All Fittings and piping are CPVC SCH. 80
- System Hydrostatically tested to ASME B31

Item	Quantity	Description
1	1	BASE: PP WHITE, 36" x 24" x 40" WITH 1/2" DRIP RIM
2	1	BOX: HOFFMAN ENCLOSURE 8" X 8" X 4", NEMA 4X
3	1	CALIBRATION COLUMN WITH SLIP-ON CAP
28	1	PRESSURE GAUGE: 0-160 PSIG, 2 1/2" DIAL WITH GK00T-5 PVDF/TEFLON DIAPHRAGM
32	1	VALVE: BACK PRESSURE, 1/2", SW, CPVC / VITON
33	9	VALVE: BALL, 1/2", TU, CPVC/VITON
34	1	Y-STRAINER, 1/2", SW, CPVC/VITON